





VENTANAR is a Colombian company with global projection. Serving the aluminum curtain wall and window market since its origins in 1.980 to present, it has established itself as one of the leading companies for the engineering and manufacturing of architectural facades, participating in major projects nationwide.

Ventanar offers from conceptual design to the development of detailed engineering, manufacturing and assembly of mainly glazed facades and other complementary products for the building envelope as ceramic, aluminum composite panel and phenolic panel, succeeding in giving architects the freedom to design projects without limits, similar to those seen in big cities around the world, while achieving the bioclimatic, acoustic and aesthetic requirements that the project design team may need. Furthermore, VENTANAR offers a technical proposal for a system and product that comply with the requirements and norms, while maintaining or improving the performance of the requested product, thus offering value engineering.

From its production plant located in Giron Santander, VENTANAR is strategically located reaching national coverage and competitive times and post sales service, added to the quality of a 100% colombian product.

VENTANAR includes in its portolio 100% factory assembled UNITIZED facade systems, allowing better finishes and extra-fast supply, with a productive capacity of up to 300m<sup>2</sup>/day. These modular prefabricated systems correspond to the fifth generation of facades developed worldwide.

VENTANAR has developed its exclusive windows and doors line for housing and hospitality markets, with high performance sealing and tightness for water and air respectively, achieving the perfect balance between performance and aesthetic quality in their products, offering as well special sound attenuation products for hotels, rated up to STC51.

Due to the high production demand, VENTANAR initiated its internal expansion proccess, with the construction of two new production warehouses for the manufacturing of curtain walls, as well as coating and logistics management of its aluminum extrusions, including an automatic powder coating line that uses non-polluting and latest technolgy machinery in order to process its curtain walls, increasing its installed capacity significantly and allowing the company to set up as a major brand in the sector worldwide.

A handwritten signature in black ink, appearing to read "A. Novoa Pineda", with a stylized flourish at the end.

Andrés Novoa Pineda  
Presidente



# PRODUCT LINES

## CORPORATE LINE

Svelte 50 curtain wall (stick system)  
Modular prefabricated curtain walls  
(Unitized system)  
Ventilated (alucobond, porcelain,  
phenolic panel)  
Structural glass curtain walls (fin glass)  
Automatic doors (DITEC)  
Fixed and operable sun shades  
Structural balustrades  
Bullet proof windows



## RESIDENTIAL LINE

High end European systems for windows  
and doors  
Shower glass enclosures  
Economic window systems  
PVC window systems  
Handrails and balcony glass enclosures  
Manual and motorized retractable insect  
screens.



Ventanar<sup>®</sup>  
**UNITIZED**

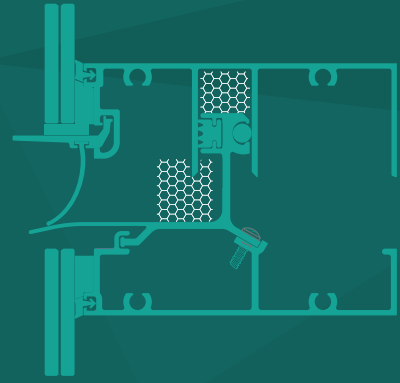

CMO - HIC | Floridablanca

Unitized preglazed modular systems, are directly glazed to the aluminum frame using sealant or mechanical fixation. This system includes a pressure controlled chamber (isobaric chamber) using the rainscreen principle (drainage system and moisture barrier) to conduct water, and a high performance silicone gasket system, reducing on-site sealant use. The installation process is three times more efficient compared to traditional systems. Each module is fully assembled and installed with SS 304 stainless steel screws.

Each module is fully assembled and installed with SS304 stainless steel screws. The tridimensional anchorage system allows the curtain wall to support +/- 25 mm plumbness tolerances, +/- 6mm in level alignment and +/- 40 mm vertical misalignment, reducing and facilitating leveling works done in the construction site, resulting in fast and optimal solutions to any installation requirement, and allowing tridimensional leveling of the facade.

Mullion

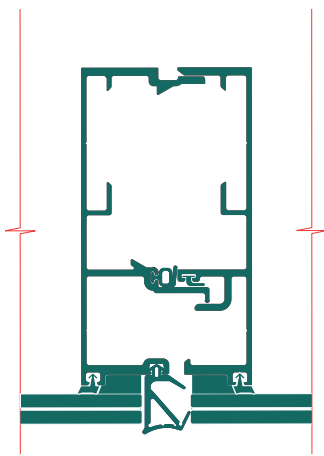

Transom

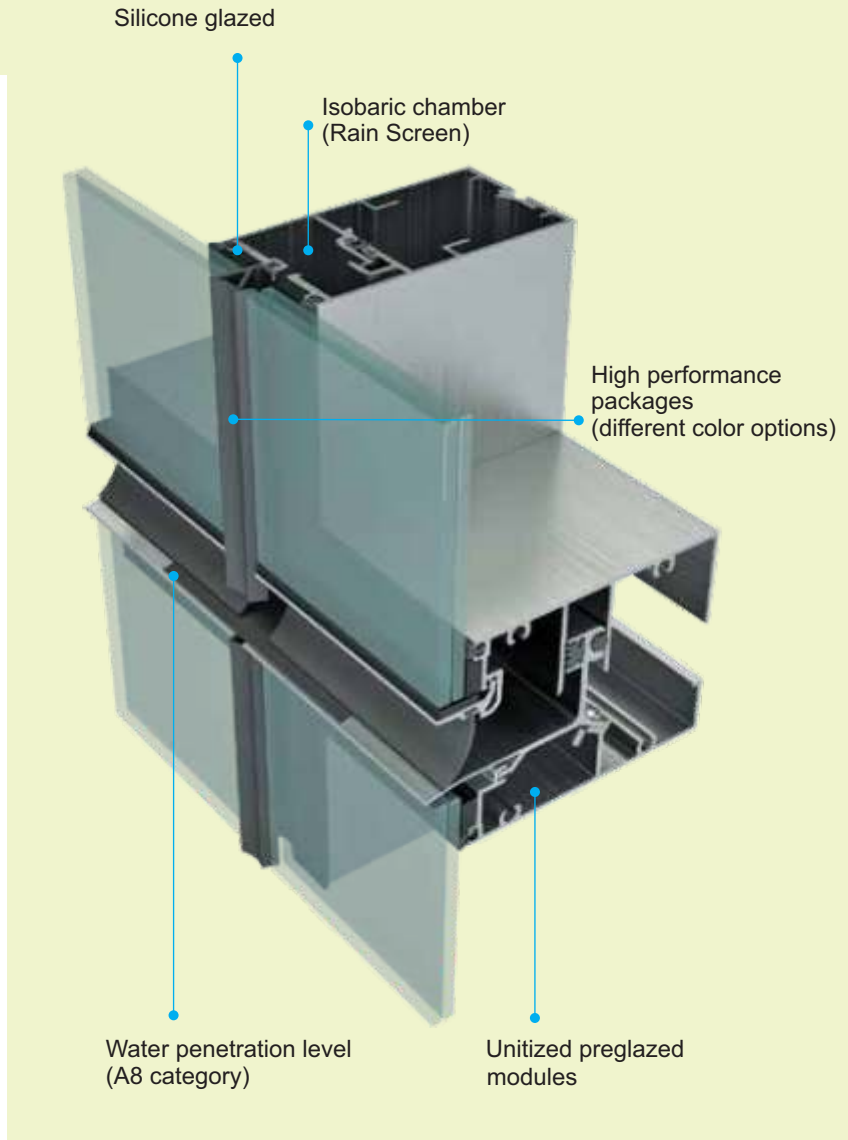
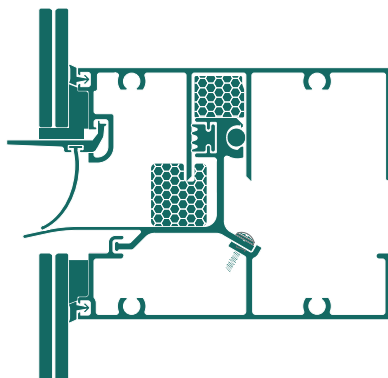

The vertical couplings in each module are sealed each other by a gasket system which controls water penetration and conduction, providing A8 level for water penetration in curtain walls according to ASTM E331 and EN 12208 for over 600 Pa, and C3 structural performance according to ASTM ED 330 and EN 12207 for over 660 Pa. These values provide an excellent product performance, reducing future maintenance requirements.



The simply supported anchorage system allows the facade to resist any building drift in case of seismic forces. Thanks to its performance, the product is catalogued as SUPERIOR according to the NSR-10 chapter A.9.

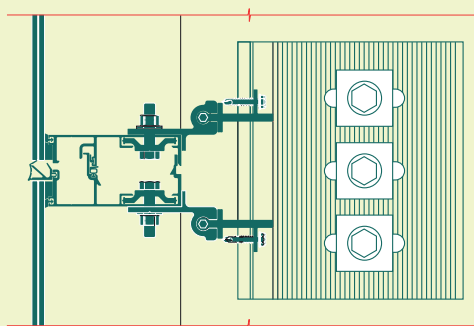
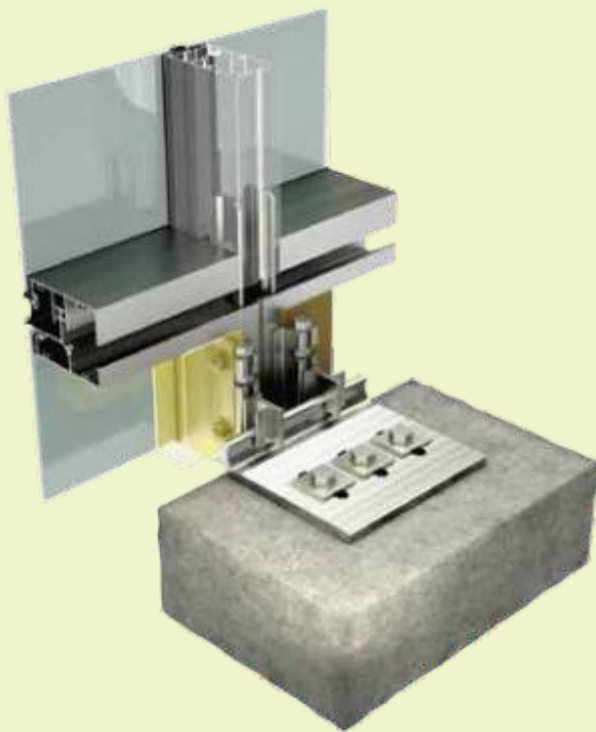

Heavy facade

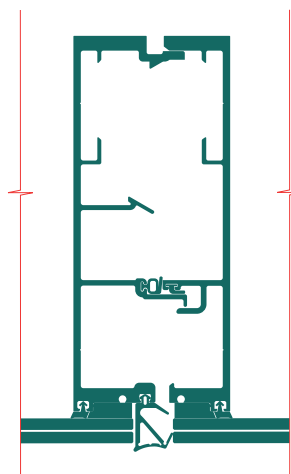

Outer corner

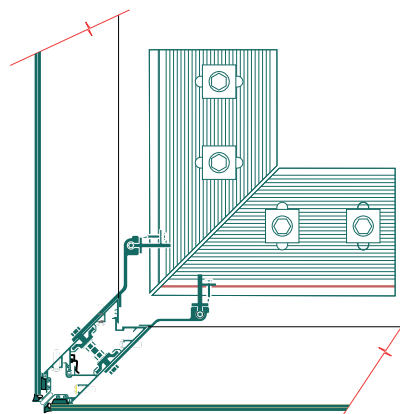

The UL certified firestop system meets the NFPA 5000 requirements: thermal rockwool protection plates (120 kg/m density) and minimal 2" thickness, installed between the building slabs.

Smoke-tight system with rockwool ribbon with minimal vertical 4" section (101.6 mm) located horizontally and sealed with elastomer putty against the slab, which activates at temperatures above 120°C, meeting the NSR-10 chapter J requirements.

# INSTALLATION SYSTEM

Unitized facade system allows a faster installation in order to achieve an agile and effective process, transporting the factory assembled panels with special lifting equipment. Ventanar counts with 8 electric hoists and a special spider mini crane designed for narrow access spaces.



Spider Crane



Electric platforms



Panel lifting